

Non-Contact Temperature Measurement

DIGITAL – INFRARED – PYROMETER

Temperature range 550 to 4000°C (1022 - 7232°F)

**Temperature control during production process
compact units – Infrared – measuring transducer and electronic process
unit in one case with light beam aiming device,
fiber optic, serial interface, limit output**

Series KTRD 1485



MAURER – Infrared – pyrometer can also assist you to monitor your heating processes, ensuring a uniform standard of quality for your products.

leaflet KTRD 1485



<http://www.maurer-ir.de>

**Dr. Georg Maurer
GmbH
Optoelektronik**

**Industriegebiet 10
D-72664 Kohlberg**

**Telefon +49(0)7025-9219-0
Telefax +49(0)7025-9219-20
Email: info@maurer-ir.de**

Infrared-Digital-Pyrometer Series KTRD 1485

More than 60 years experience in the area of non-contact temperature measurement and permanently development of the pyrometers makes it possible to offer you a complete program of field tested units..
Mainly for **fast warming processes contactless temperature measurement** is suitable.

The **series KTRD 1485** are **digital part radiation pyrometer** with fiber optic and optic system in compact structure likewise suitable for industry, research and laboratory.

With the integrated light beam aiming device (green LED) an adjusting of the pyrometer to the measuring object is very easy.

The temperature linear analog output signal 0/4 up to 20 mA is available for measuring- and controlling purposes. The simultaneous using of the serial interface with the software IR-LOG enables the data detection, graphical representation and the parameter settings of the pyrometer.

Examples for applications:

steel, iron, non-ferrous metal, wires, glass feeder, glass tub, glass arching, hardening, induction heating, ceramics, soldering, forging, welding, transforming, vacuum-furnace, rolling etc.

Technical datas:	KTRD 1485			
Unit types	light beam aiming device green LED			
Target marking	light beam aiming device green LED			
Temp. measuring ranges:	MR1: 550-1800°C 1022-3272°F	MR2: 600-2000°C 1112-3632°F	MR3: 650-3000°C 1202-5432°F	MR4: 700-3500°C 1292-6332°F
Spectral range	0,85 - 1,1 µm			
Response time (t95)	<10 ms			
Measuring uncertainty	0,5% of meas.value in °C ± 1°C (ε = 1, Tamb. = 23°C, T 95 = 1s)			
Reproducibility	0,1% of meas.value in °C ± 1°C (ε = 1, Tamb. = 23°C, T 95 = 1s)			
Emission factor ε	100 - 10 % adjustable at the unit or through interface			
Analog output	0 - 20 mA or 4 - 20 mA , load max. 500R			
Part measuring ranges:	free adjustable within the measuring range			
Resolution	< 0,1% analog output, < 0,1°C at interface			
1 limit output (open coll.)	24 V DC / max. 100 mA			
Max.reading memory	max.memory, double memory,adjustable time and threshold value, erasing after time, external contact, by software, after new meas.part			
Interface	RS 232 ± 50 V isolated			
Software IR-LOG	data recording, graph.representation, setting of pyrometer parameters			
adjustable parameter with Software IR-LOG	emissionfactor,switching output,analog output, part meas.range, °C/°F, max.memory, average value, light beam aiming device switchable			
Fiber optic	length 1800mm, bend radius min. 40 mm, (other length on request)			
Objectives	for accommodation to the measuring application an extensive selection of objectives are available			
Working temperature	pyrometer 0-50°C (32-122°F), fiber optic, optic system up to 150°C(302°F)			
Stock temperature	- 10°C - + 70°C (14-158°F)			
Temperature sensitivity	0,05 % / °C			
Humidity tolerance	35 - 85 % RF (non condensing)			
Operating voltage	24 V DC ± 10 % or 18 V AC ± 10 % < 160 mA			
Unit connection	12-pole plug-connector			
Dimensions: H / W / D	54 x 54 x 147 mm (2,13 x 2,13 x 5,79 inch) ALU-case			
Weight	0,6 kg (1,32 lbs)			
Protection grade	IP 65			

mechanical assembly	electrical assembly	
Execution in cooling case	AE 1010 electr.process unit	digital display (built in-execution)
Blowing device	AE 1012 electr.process unit	connection cable 12-pole
Mirror 90°	power supply 230VAC - 24 VDC	
Mounting parts		

Objectives for units with fibre optic cable KTRD 1465/1475/1485

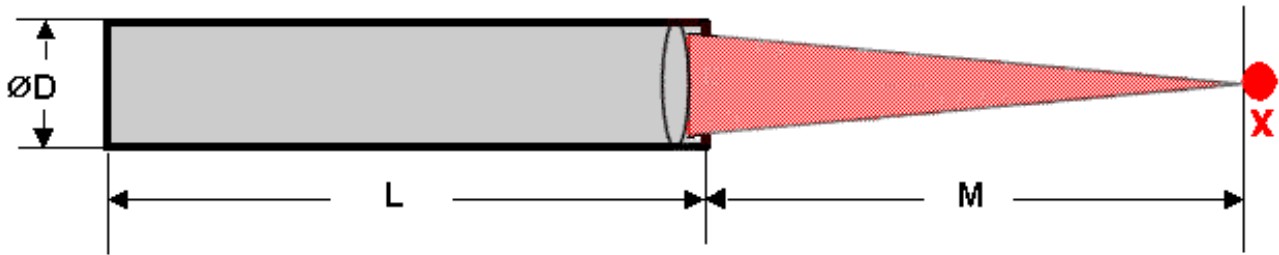

Fibre bundle $\varnothing 1,1 \text{ mm}$ / $\varnothing 2,0 \text{ mm}$ / $0,5 \times 2,7 \text{ mm}$

For determination of the respective target size X the fibre optic bundle must be multiplied by the magnification factor of the optic system.

Article-No.:	Optic-type:	\varnothing D mm	Meas. distance M mm	zoom factor V	length L mm
116-1206	VL 20 M	11	20	1,0	49,5
116-1068	VL 40 M	11	40	1,0	67,0
116-1207	VL 60	11	60	1,5	62,5
116-1208	VL 50 M	18	50	0,6	127,0
116-1028	VL 100 M	18	100	1,0	120,0
116-1029	VL 160	18	160	1,6	157,0
116-1209	VL 200	18	200	2,0	144,0
116-1050	VL 250	18	250	2,5	132,5
116-1210	VL 300	18	300	3,3	125,5
116-1211	VL 400	18	400	4,5	119,0
116-1071	VL 500	18	500	4,0	152,0
116-1212	VL 600	18	600	6,0	146,5
116-1213	VL 1000	18	1000	9,5	138,0
116-1214	VL 1500	18	1500	13,6	135,0
116-1215	VL 100 M	25	100	1,0	127,5
116-1216	VL 160	25	160	1,5	123,0
116-1217	VL 200	25	200	2,0	226,0
116-1218	VL 250	25	250	2,5	147,0

(special objectives on request)

Dr. Georg Maurer GmbH – OPTOELEKTRONIK –
 Industriegebiet 10 D-72664 Kohlberg Telefon +49(0)7025-9219-0 Telefax +49(0)7025-9219-20



Reg.-Nr.: Q1 0201014

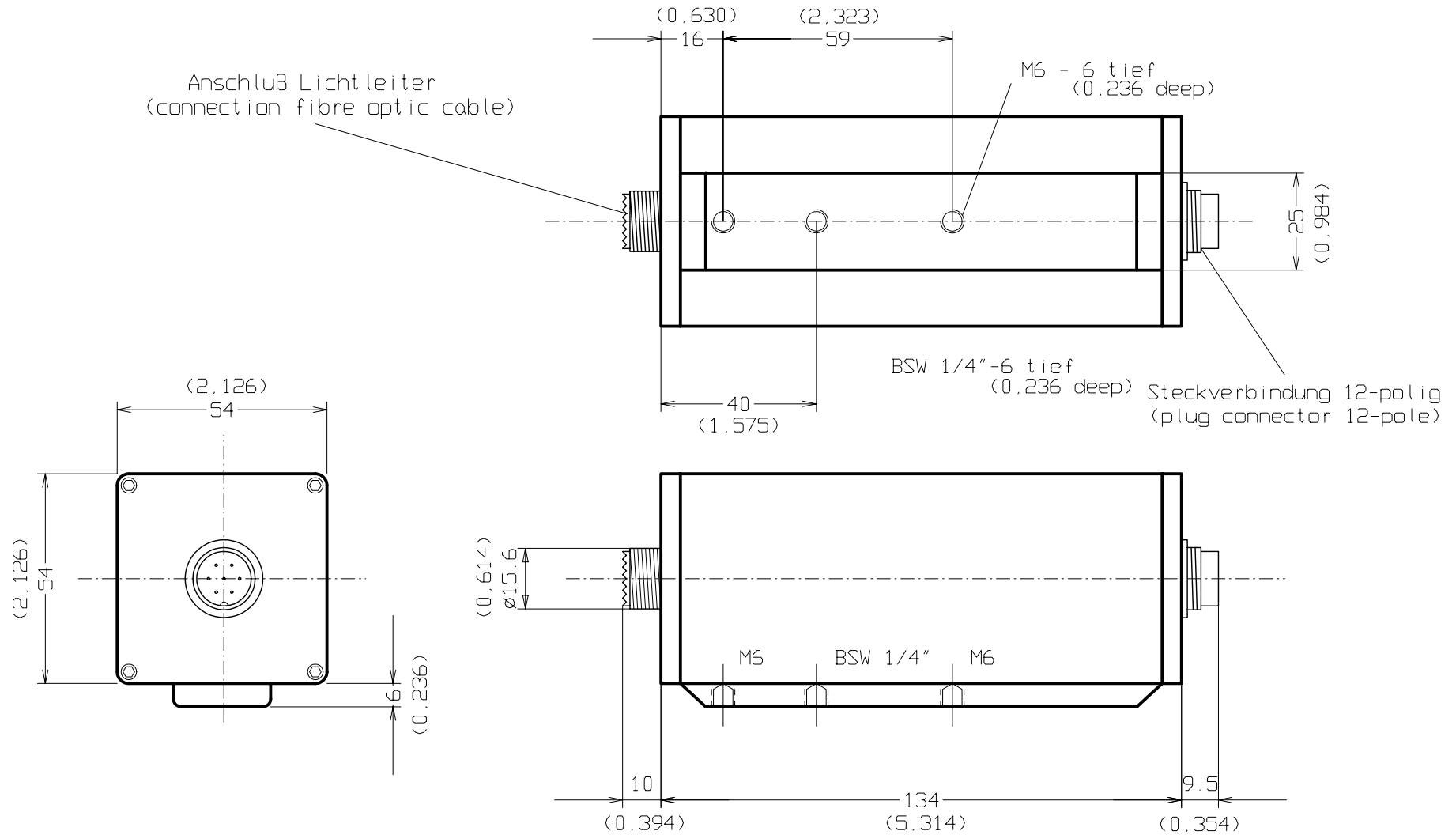

(xxx) - Maße in Zoll
(dimensions inch)

		Maßstab 1:1	
		Fa.Dr. Maurer GmbH	
		STANDARDGEHÄUSE (standard case) KTRD 1400	
		091103	
		Blatt	
		Bl.	
Zust	Änderung	Datum	Name